



Description



General Features :

- BHSP model Pipe Feeding Housing is designed for rolling of pipe workpiece over it.
- BHSP model Pipe Feeding housing as standard 1000 kg. is presented.
- BHSP model, According to customer requests, Special productions are manufactured in various diameters & capacities..
- BHSP model equipment is predominantly designed as feeding of pipes in horizontal-vertical and angular regions in long distance laying of pipes.
- An indispensable solution in construction sites & working areas.
- Operators can work more effective and efficient.

Technical Details :

Model : BHSP	Sym	Unit	BHSP-1
Load Capacity		kg	1000
Min.-Max.Rotating Diameter	$\varnothing D_{min} - \varnothing D_{max}$	inch	4" – 24"
Width	A	mm	400
Length	B	mm	380
Weight		kg	37

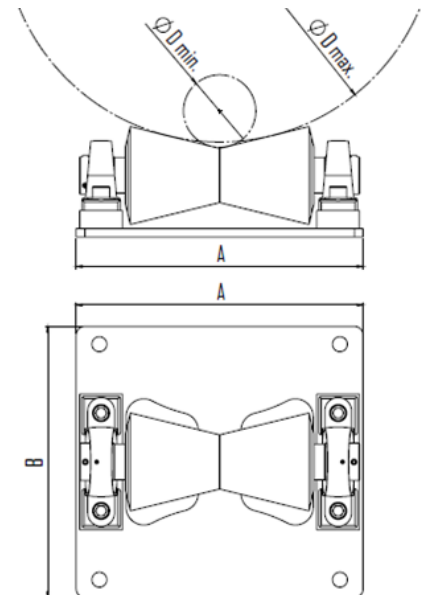

↪ Out of these std. capacities, Birel Machinery, according to customer requirements has the manufacturing possibility at different capacities, sizes.

❖ All technical specifications are subject to change without prior notice.